



- OPENABLE FRONT & SIDE COVERS
- 1 OR 2 VENTILATION FANS
- TWO DEPTH OPTIONS 450mm & 600mm
- AVAILABLE IN 4U, 6U, 9U, 12U & 15U
- IMPACT RESISTANT PAINT
- TOP, BOTTOM & REAR CABLE ENTRY

## **EVT-C-xxxx SERIES**

### WALL MOUNTED CABINETS



# EVT-C-xxxx SERIES WALL MOUNTED CABINETS

## 19" (600x450) mm Series

EVT Part Number	U Form-Factor	Inner Height (mm)	Outer Height (mm)	Weight (kg)
EVT-C-6404	4U	179.4	236.4	11
EVT-C-6406	6U	269.1	326.1	13
EVT-C-6409	9U	403.7	460.7	16
EVT-C-6412	12U	538.3	595.3	19
EVT-C-6415	15U	672.9	729.9	22

## 19" (600x600) mm Series

EVT Part Number	U Form-Factor	Inner Height (mm)	Outer Height (mm)	Weight (kg)
EVT-C-6604	4U	179.4	236.4	16
EVT-C-6606	6U	269.1	326.1	18
EVT-C-6609	9U	403.7	460.7	21
EVT-C-6612	12U	538.3	595.3	25
EVT-C-6615	15U	672.9	729.9	30

## ASSEMBLY VIEW & ACCESSORIES

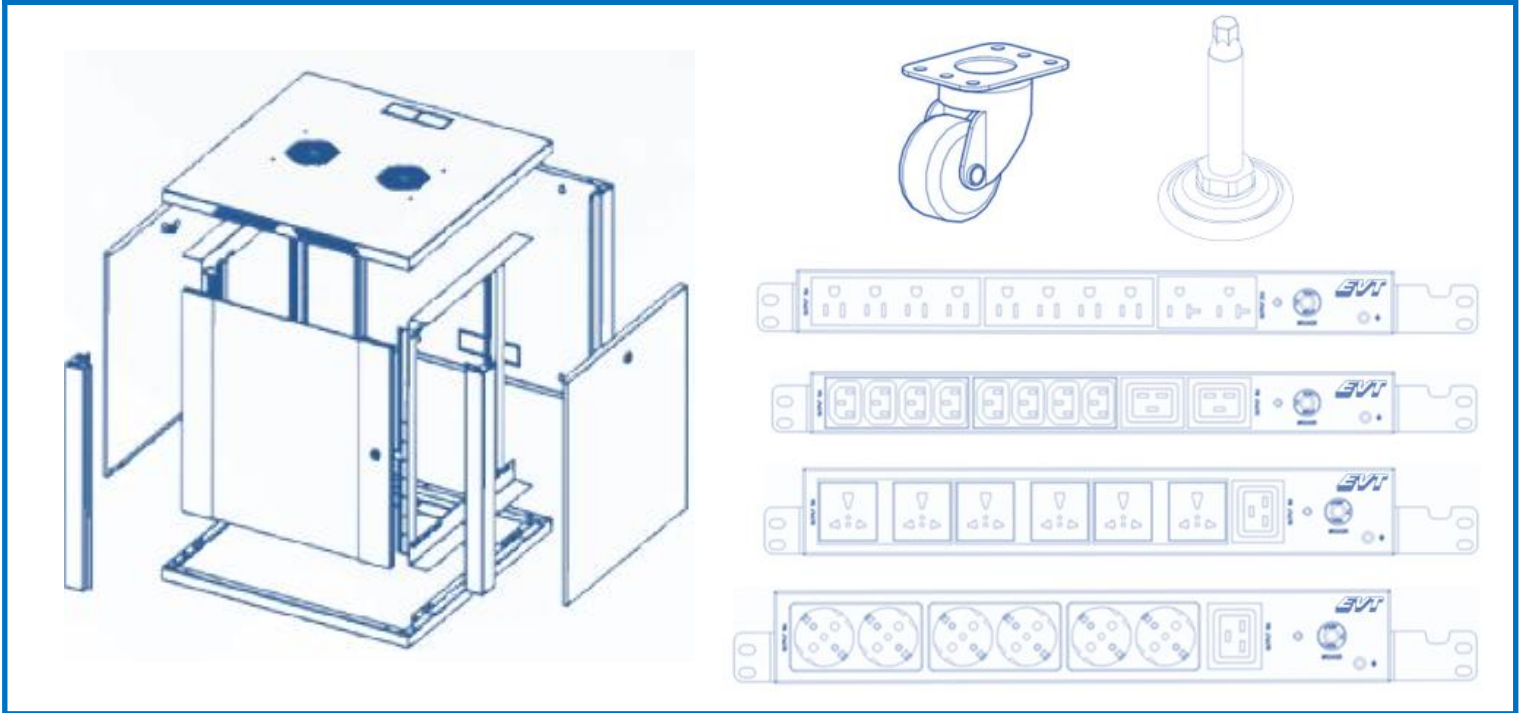

All rights reserved. Appearance and specifications are subject to change without prior notice

**Eagle Vision Technology Co.**  
 938 N. 200th St., Suite B, Shoreline-Seattle  
 WA 98133, UNITED STATES  
 Tel: 1-800-204-4012  
 www.eaglevisiontech.com  
 sales@eaglevisiontech.com

Distributed By